

Phalanx™ Alpha Phalanx™ Beta and Ultra Elite®

riot control agent gas masks

instructions

parts list

NIOSH approved for respiratory protection in atmospheres containing CN and CS and particulates under the 42 CFR 84 P100 classification (99.97% efficiency level) against all particulate aerosols, including oil-based aerosols.

NIOSH approval

**See inside for instructions, warnings and limitations.
See separate insert for NIOSH Approval Matrix.**

For More Information, call 1-800-MSA-2222 or Visit Our Website at www.MSAnet.com



**MINE SAFETY APPLIANCES COMPANY
PITTSBURGH, PENNSYLVANIA, U.S.A. 15230**

NIOSH CAUTIONS AND RESPIRATOR USE LIMITATIONS

- A- Not for use in atmospheres containing less than 19.5 percent oxygen.
- B- Not for use in atmospheres immediately dangerous to life or health.
- C- Do not exceed maximum use concentrations established by regulatory standards.
- I- Contains electrical parts which have not been evaluated as an ignition source in flammable or explosive atmospheres by MSHA/NIOSH.
- J- Failure to properly use and maintain the product could result in injury or death.
- L- Follow the manufacturer's User's Instructions changing cartridges/and or filters.
- M- All approved respirators shall be selected, fitted, used, and maintained in accordance with MSHA, OSHA, and other applicable regulations.
- N- Never substitute, modify, add, or omit parts. Use only exact replacement parts as specified by the manufacturer.
- O- Refer to User's Instructions, and/or maintenance manuals for information on use and maintenance of these respirators.

Follow any applicable limitation contained in a standard established by a regulation agency (such as OSHA) with jurisdiction over the wearer.

INSTRUCTIONS FOR USE AND CARE

OPERATING PRINCIPLE

This gas mask, when properly used, removes harmful gases, vapors (NIOSH approved for CN, chloroacetophenone and CS, chlorobenzylidene malononitrile) and all particulate aerosols, including oil based aerosols, (listed on the canister label) from the inhaled air. Inhaled air is drawn through the canister which contains chemicals and a P100 filter that removes or neutralizes the contaminants. The air is then drawn through the facepiece, where it passes over the lens (to minimize fogging) before it is taken into the lungs. Exhaled air leaves the facepiece through an exhalation valve and consequently is not rebreathed.

⚠ WARNING

- 1. This device does NOT supply oxygen, and must only be used in adequately ventilated areas containing at least 19.5 percent oxygen.**
- 2. This respirator must be used in conjunction with the proper canister for protection against specific contaminants.**
- 3. Leave area immediately if:**
 - A. Breathing becomes difficult.**
 - B. Dizziness or other distress occurs.**
 - C. You taste or smell contaminant.**
 - D. You experience eye, nose or throat irritation.**
- 4. Use strictly in accordance with instructions, labels and limitations pertaining to this device.**
- 5. This respirator may not provide a satisfactory seal with certain facial characteristics, such as beards or large sideburns, that prevent direct contact between the skin and the sealing surface of the facepiece. Do not use this respirator if such conditions exist.**

6. **Never alter or modify this device.**
7. **This respirator is for use by trained, qualified personnel only.**
8. **This facepiece does not provide any protection against propelled or falling missiles. Consequently in riot or similar situations it is imperative that a riot faceshield be worn in conjunction with the mask for protection against propelled or falling missiles.**

**FAILURE TO FOLLOW THE ABOVE WARNINGS CAN
RESULT IN SERIOUS PERSONAL INJURY OR DEATH.**

Respirator Fit Test

A qualitative or quantitative respirator fit test must be performed for each wearer of this respirator to determine the amount of protection it will provide. Respirator fit tests are explained fully in the American National Standard for Respiratory Protection, ANSI Z88.2, which is published by the American National Standards Institute, 11 West 42nd Street, New York, New York 10036.

Quantitative Test

If a quantitative fit test is used, a fit factor that is at least 1000 shall be obtained before that respirator is assigned to an individual.

Qualitative Test

If a qualitative fit test is used, only validated protocols are acceptable. The individual must pass a test designed to assess a fit factor of at least 1000.

 WARNING

The user must perform a respirator fit test and follow all warnings and limitations specified. Failure to do so can result in serious personal injury or death.

PREPARATIONS FOR USE

There are five inspection points, listed below, that must be checked before donning the respirator. Under no circumstances should a respirator that fails inspection be used. The respirator must be repaired or replaced.

1. **Head harness:** Check to see that the head harness straps still have their elasticity. Inspect for cracks or tears and make sure all buckles are in place and working properly.
2. **Facepiece:** Check facepiece for dirt, cracks, tears or holes. Inspect the shape of the facepiece for possible distortion that may occur from improper storage and make sure the rubber is flexible, not stiff.
3. **Inhalation and exhalation valves:** Check for cracks, tears, distortion, dirt or build-up of material between valve and valve seat.
4. **Facepiece inlet port:** Check to make sure gaskets are in place (if applicable) and check for cracks and damage to threads.
 - a. **Inlet Port (Phalanx Beta only):** Check to make sure gasket is in place and check for traces of damage to inlet components.
 - b. **Inlet Port (Phalanx Alpha only):** Check to make sure the inlet port threads are free of damage such as crossed threads and that the canister sealing surface of the facepiece is clean and free of dirt or other foreign matter. Make sure the inlet port plugs are in place on the side of facepiece opposite the canister.

5. Canister: Make sure canister is clean. Never try to clean canister by washing it or using compressed air. Inspect canister for dents, scratches or other damage.

Assemble Gas Mask as Follows:

Place canister onto inlet port carefully. Hand tighten by turning clockwise to ensure a good seal against the gasket or facepiece.

DONNING THE MASK

1. Extend all headband straps.
2. Put you chin in first.
3. Grasp the two side straps in each hand, and pull the harness back over your head.
4. To tighten straps, pull straight back, not out.
5. Adjust straps as necessary to position facepiece.

TEST FOR TIGHTNESS

THE FACEPIECE MUST BE SUBJECTED TO THE FOLLOWING TIGHTNESS TEST BEFORE EACH USE. Test the mask facepiece for tightness by lightly placing a palm over the inlet end of the canister. Inhale gently so that the facepiece collapses slightly and hold breath for ten seconds. The facepiece will remain collapsed while the breath is held providing the assembly is gas tight. If any leakage is detected around the facial seal, readjust head harness straps and repeat test until there is no leakage. If other than facial seal leakage is detected, the condition must be investigated and corrected before another test is made. The facepiece must pass the tightness test before the user should attempt to enter any toxic atmosphere. The mask will not furnish protection unless all inhaled air is drawn through the canister.

▲ WARNING

Do not enter any atmosphere with this respirator unless you KNOW that:

1. You have read, understood and followed all instructions and warnings pertaining to the respirator.
2. The respirator and conditions meet the requirements outlined.
3. The canister is the proper type for the contaminant or contaminants present.
4. The amount of oxygen is sufficient to support life (that is, at least 19.5 percent oxygen by volume at sea level). Do not use if oxygen concentration sufficient to support life is questionable.
5. Respirator does not leak (see Test for Tightness).
6. Canister does not need to be replaced. Discard exhausted canister.

**FAILURE TO FOLLOW ABOVE WARNINGS CAN
RESULT IN SERIOUS PERSONAL INJURY OR DEATH.**

REPLACING THE CANISTER

Due to the uncontrolled environment, the canister along with the P100 filter must be replaced after each use. During use, the length of time the chemicals in the canister will give protection depends both on the concentration of the contaminants and the rate of breathing. When the mask is properly adjusted, leakage as indicated by odor, taste or eye, nose or throat irritation is evidence that the canister is exhausted. Excessive inhalation resistance is also evidence that the canister has served its useful life and must be replaced. The wearer should return immediately to fresh air and attach a new canister. Do not use canister after the expiration date on label.

USING THE INLET PORT PLUG (Phalanx Alpha Version only)

The design of this gas mask allows the user to wear the gas mask with the canister on either the right side or the left side of the facepiece. The threaded receptacle on the side of the facepiece opposite from the side on which the canister is mounted must be sealed off by the inlet port plug. The inlet port plug must be tightened by turning clockwise onto the threaded inlet port, on which the canister is creating a seal between cap and facepiece.

MAINTENANCE

This mask must be kept in good condition to function properly. When any part shows evidence of failure, it must be replaced immediately with the proper part.

CLEANING AND DISINFECTING

The facepiece assembly (with canister removed) should be cleaned after each use with MSA Cleaner-Disinfectant Liquid (P/N 697284) (maximum 120°F).

1. Immerse soiled equipment in the solution and scrub gently with a soft brush until clean. Take care to clean the exhalation valve in the facepiece and all other parts that exhaled air contacts.
2. Rinse in plain warm water (maximum 120°F) and then air dry.

CAUTION

Cleaning at or below 120°F will avoid possible overheating and distortion of parts of the respirator which would require replacement.

STORAGE

This mask, when not in use, should be kept in the container provided.

RESPIRATOR USE LIMITATIONS IN CBA (CHEMICAL - BIOLOGICAL WARFARE AGENT) ATMOSPHERES:

The recommended work environments for this respirator include operations where exposure to vapor or liquid Chemical Agents or Biological Agents is possible but not expected, or, for escape from possible CBA contamination and controlled low level CBA atmospheres which do not exceed the maximum use concentration as determined by the governing authority.

In the event a maximum use concentration has not been established by the governing authority, it is recommended that the use of the respirator should be

limited to atmospheres 100 times (or less) the defined permissible Airborne Exposure Limit (AEL) or Time Weighted Average (TWA) of the contaminate (except for mustard and lewisite, for these agents the recommended use concentration is to be limited to the AEL or TWA).

⚠ WARNING

For uses in atmospheres containing chemical or biological warfare agents, as with all hazardous atmospheres, it is recommended that a complete respiratory and body protection program be developed and full protective ensemble be utilized. This program should as a minimum include the following items:

Before Entering a CBA Contaminated Area

1. All users should be trained (on a regular basis) in the use of the protective equipment, the hazard, the effects and physical signs of agent over exposure, governing protocols or regulations concerning the hazard and user, medical needs, emergency and first aid procedures in case of over exposure, decontamination, and handling and disposal of contaminated equipment.
2. Each user should be quantitatively fit tested in the facepiece they will be using and have a tested fit factor of 1000 or greater.
3. It is recommended that each user should be outfitted with a facepiece with CBA canister, a hood, and full chemical protective suit including gloves and shoe coverings.
4. The user should determine or check with the safety office to verify that the protective equipment to be used is sufficient for exposure to their particular hazard and contamination level. Mis-use of the protective equipment can result in serious personal injury or death.

During the Stay in the CBA Contaminated Area

1. It is recommended that the area be real time monitored (with alarm) for exposure levels of the contaminate. If the monitored contaminate level is above the allowable exposure limit or maximum use concentration (as determined by the governing protocol), the user should leave the area immediately.
2. The user should not remove any of the CWA protective clothing while in the contaminated area. This action could result in a serious injury or death.
3. If symptoms of CBA over exposure are present, seek medical treatment and attention immediately.

After Exposure to a CBA Contaminated Area

1. A decontamination procedure for the user and the protective equipment should be developed and implemented.
2. Once the user leaves the contaminated area, they should enter the decontamination area and follow the set decon procedure. Failure to follow an acceptable decon procedure could lead to serious injury or death.
3. Once the user and the protective equipment have been decontaminated, proper disposal of affected equipment is to be performed. Disposal is to be performed as required by federal, state and/or local laws that apply to CBA contaminated materials.

⚠ WARNING

Failure to follow accepted safety and protection procedures when exposed to hazardous atmospheres, can result in serious personal injury or death.

Phalanx™ Alpha Gas Mask Components

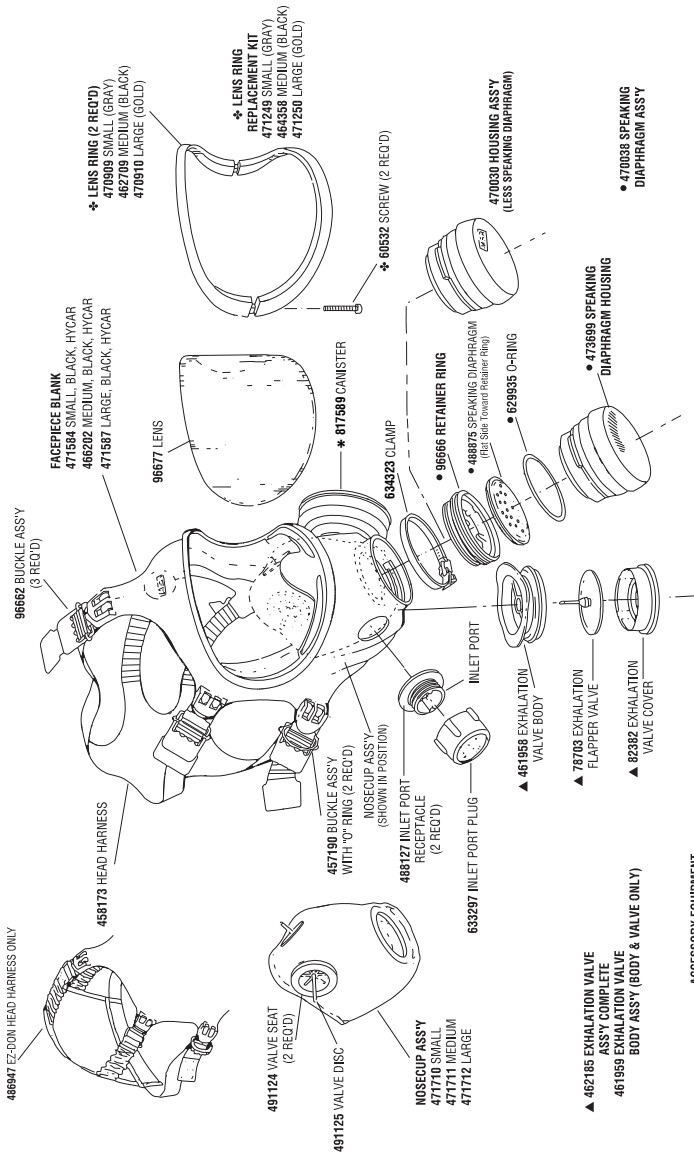

* SOLD IN PACKAGE OF 6 P/N 817591

ACCESSORY EQUIPMENT
 459875 COVER LENS (CLEAR) 25/PKG.
 459879 SPECTACLE KIT

Phalanx™ Beta Gas Mask Components

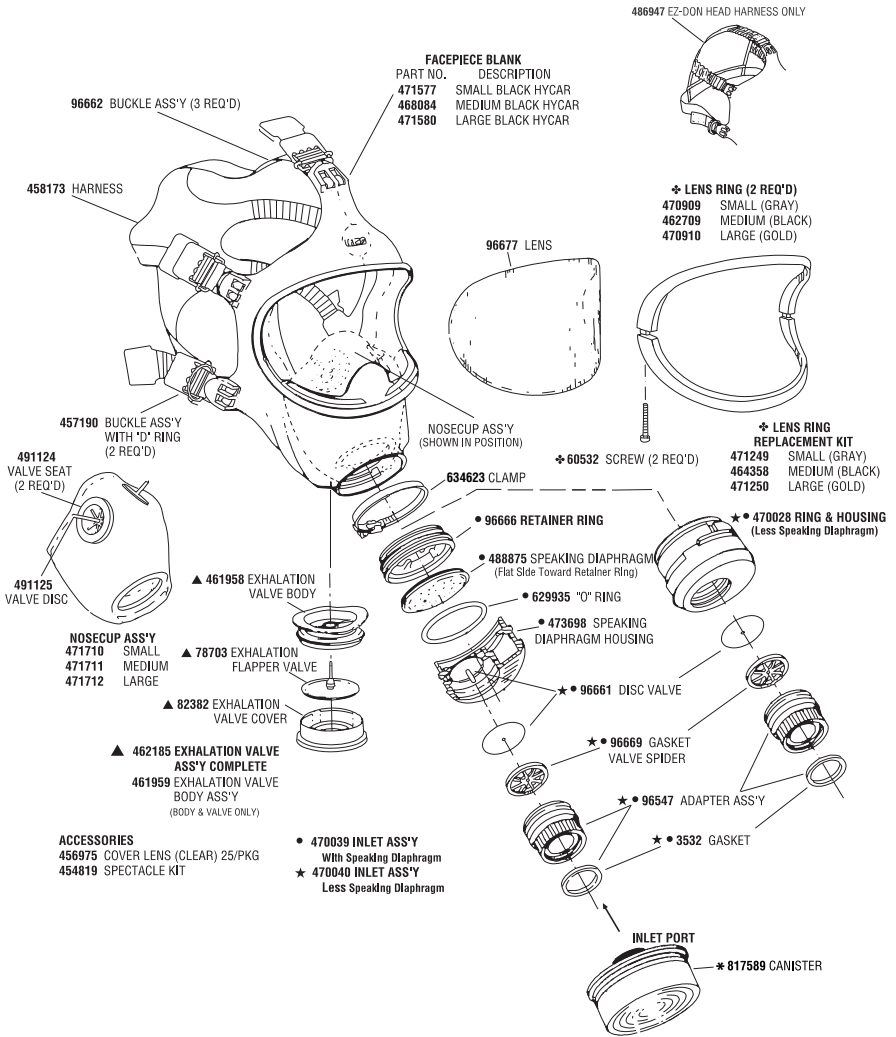

Ultra Elite® Gas Mask Components (Phalanx™ Beta Version)

Facepiece Components

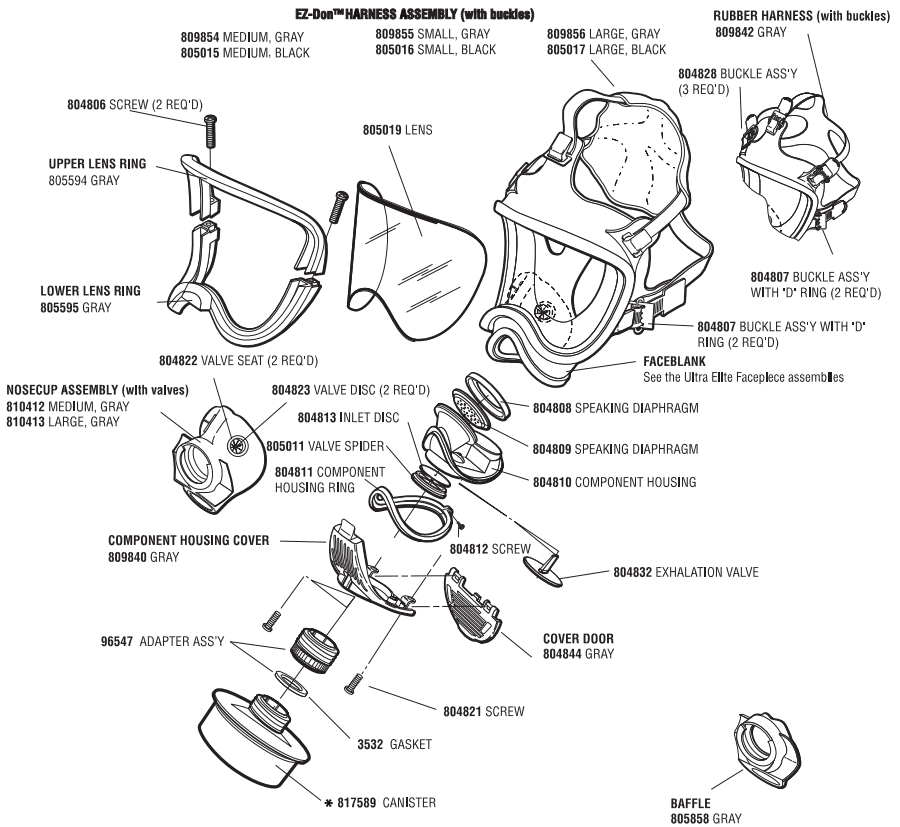

* SOLD IN PACKAGE OF 6 P/N 817591

NOTES

For More Information, call 1-800-MSA-2222 or Visit Our Website at www.MSAnet.com



MINE SAFETY APPLIANCES COMPANY
PITTSBURGH, PENNSYLVANIA, U.S.A. 15230

